

ПРЕДПРИЯТИЕ МАКСАЭРО

- Производство воздуховодов и систем вентиляции
- Клапаны противопожарные
- Клапаны дымоудаления
- Вентиляторы общепром, дымоудаления, крышные

220056, г. Минск, ул. Стариновская, 15

Тел./факс: +375 17 244-67-44, 258-67-51, 347-73-56, 252-54-27

Velcom: +375 29 603-88-99

E-mail: olegaero@yandex.by

www.maxaero.by



Мембранные пневматические насосы Debem Voxer и Cubic



Main advantages

The **CUBIC diaphragm mini pumps** and the **BOXER diaphragm pumps** feature high levels of performance. Their considerable power and sturdiness render them ideal for pumping highly viscous liquids, even with suspended solids. The pneumatic stall-prevention circuit guarantees a safe operation, without requiring lubricated air. These pumps have achieved unprecedented levels of versatility due to their dry self-priming capacity with a considerable suction head, the ability to fine-tune the

speed without losses of pressure as well as the possibility of empty-running without suffering damage. The vast range of construction materials allows us to select the best chemical compatibility with the fluid and/or the environment, without neglecting the operating temperature range. **Their construction principle makes them ideally suited for demanding applications with high levels of humidity or in potentially explosive atmospheres (ATEX and IECEx certification).**

- Constructed in PP, PP+CF, PVDF, ECTFE, PTFE, ALUMINIUM, AISI 316 STAINLESS STEEL, AISI 316 L STAINLESS STEEL
- Use in explosive atmospheres (ATEX certification zone 1 – 2, IECEx certification)
- Suitable for demanding applications and in atmospheres with high levels of humidity
- Dry-running
- Dry self-priming
- Supply with non-lubricated air
- Patented stall-prevention pneumatic circuit
- Adjustable flow rate and head
- Fine adjustment of the speed at constant pressure
- Possibility of split manifolds (two suctions and two deliveries)
- Bench or ceiling installation
- Customisable positions
- Easy maintenance and parts replacement
- Excellent ratio between performance and costs
- Operating temperature:
 - PP / PP+CF from +3°C to +65°C
 - PVDF / ECTFE from +3°C to +95°C
 - AISI 316 / AISI 316 L / Aluminium from +3°C to 95°C

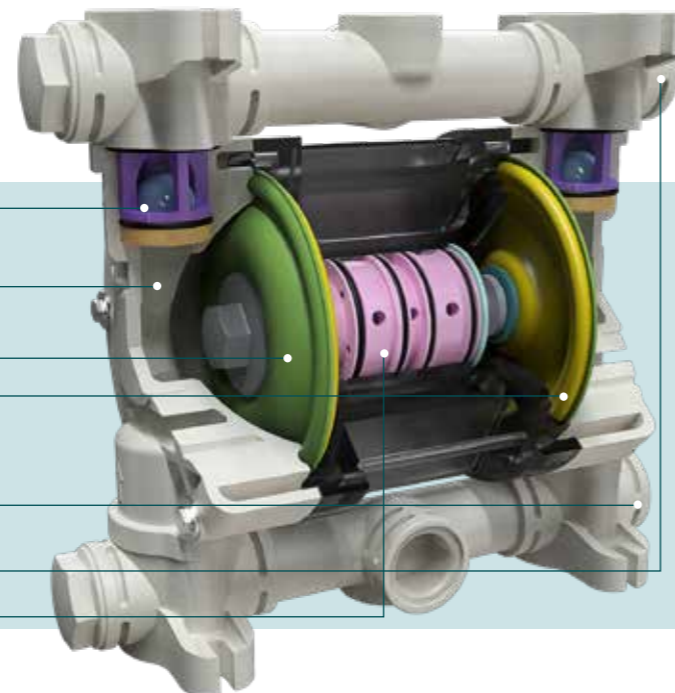

- A = ball valves
- B = pumping chamber
- C1 = product-side diaphragm
- C2 = air-side diaphragm
- D = suction manifold
- E = delivery manifold
- F = pneumatic exchanger

BOXER DIAPHRAGM PUMPS AND CUBIC DIAPHRAGM MINI PUMPS

PLASTIC BOXER



- ATEX ZONE 1 - AVAILABLE ON REQUEST
 - II 2G Ex h IIB T4 Gb
 - II 2D Ex h IIIB T135°C Db X
 - Ex h IIB T4 Gb
 - Ex h IIIB T135°C Db
- ATEX ZONE 2 - STANDARD ON ALL MODELS
 - II 3G Ex h IIB T4 Gc
 - II 3D Ex h IIIB T135°C Dc X
 - I M2 Ex h I Mb X

IECEx

The plastic BOXER range is designed for demanding uses, for very aggressive and acid liquids, in the numerous applications of the chemical industry.

MATERIALS PP, PP+CF, PVDF, ECTFE, PTFE
Max dry suction 5m



METAL BOXER



- ATEX ZONE 1 - AVAILABLE ON REQUEST
 - II 2G Ex h IIB T4 Gb
 - II 2D Ex h IIIB T135°C Db X
 - Ex h IIB T4 Gb
 - Ex h IIIB T135°C Db
- ATEX ZONE 2 - STANDARD ON ALL MODELS
 - II 3G Ex h IIB T4 Gc
 - II 3D Ex h IIIB T135°C Dc X
 - I M2 Ex h I Mb X

IECEx

The metal BOXER range is designed for demanding uses, for solvent-based liquids and for numerous uses in the paint industry.

MATERIALS ALUMINIUM, AISI 316 STAINLESS STEEL, AISI 316 L STAINLESS STEEL
Max dry suction 5m



CUBIC



- ATEX ZONE 1 - AVAILABLE ON REQUEST
 - II 2G Ex h IIB T4 Gb
 - II 2D Ex h IIIB T135°C Db X
- ATEX ZONE 2 - STANDARD ON ALL MODELS
 - II 3G Ex h IIB T4 Gc
 - II 3D Ex h IIIB T135°C Dc X

This range of pumps, with their unique design and compact dimensions, can be used in series in small spaces.

MATERIALS PP, PP+CF, ECTFE
Max dry suction 3m



PATENTED STALL-PREVENTION COAXIAL PNEUMATIC EXCHANGER

Debem pumps use a patented stall-prevention coaxial pneumatic exchanger. This device introduces compressed air to change the equilibrium of the pressure of the diaphragms, assisted by a stall-prevention circuit, that guarantees optimal performance, even in the most critical conditions. The control part (spool) and the power part (exchanger) are both housed inside the pump in a single block, which limits further losses of load when compressed air flows in the pump. The Debem pneumatic exchanger is easy to repair and/or replace. The internal exchanger

is built entirely with plastic parts (except for the shaft connecting the two diaphragms), rendering it resistant to corrosive fluids and fumes.

The Debem exchanger is pre-lubricated, therefore the supply air for the pump does not require lubrication, quite the opposite, it must be dried and free of impurities, such as oil, dust or condensation. Debem's pneumatic exchanger (unique in its kind) is built with an extremely low number of parts, making parts replacement and maintenance extremely easy.



- Low cost of spare parts (single or kit)
- Easy installation
- Self-lubricated system
- No metal parts (only the shaft)
- Stall-prevention system
- Long life of the device: more than 50,000,000 cycles

Amongst the lowest air consumptions on the market

The air consumption data (expressed in NL/minute) of Debem's pumps are real and checked, with certified state of the art instruments and are amongst the lowest available on the market today. Debem's pumps have been specifically designed to optimise the space on the back of the diaphragms. The volumetric space profiles are developed to guarantee the total dilation of the diaphragms with very small air volumes. Debem's pumps are designed to optimise the consumption of air, regardless of whether electronic control systems are used. Our competitors sell this option as an accessory but

certain misleading advertising would have you believe that this is a production standard. Be suspicious of all companies that claim technical data without having the instruments necessary to determine their veracity.

Debem can count on its own new-concept test bench, with state of the art certified instruments, designed to test and certify the parameters of its own products and the efficiency of the pumps, in compliance with the latest applicable standards and in line with the new European project for INDUSTRIA 4.0.



The diaphragms are the parts subjected to the greatest stresses during suction and pumping, whilst also having to resist the chemical attack and temperature of the liquid and the mechanical fatigue. Their correct assessment and selection is therefore of fundamental importance for the life of the diaphragm, as well as for the investment decisions and maintenance costs. A modern design process, destructing testing, as well as an in-depth analysis of the results have allowed Debem to develop the **new generation LONG LIFE diaphragms**. Thanks to their profile and construction shape, these products offer a larger working surface and improved redistribution of the load, reducing the stress and yield of the material to a minimum.

BOXER / CUBIC FAMILY

RUBBER DIAPHRAGMS

They are produced with rubber mixtures and special additives that improve their chemical characteristics as well as their mechanical flexural and resistance characteristics. These diaphragms have a nylon cloth reinforcement that improves stress distribution.

NBR

Inexpensive and particularly suited for petroleum-based liquids, oil and abrasive fluids.

EPDM

Good resistance to acids, alkaline and abrasion as well as a good flexibility also at low temperatures.



BOXER FAMILY

THERMOPLASTIC DIAPHRAGMS

Made with thermoplastic polymers, these diaphragms provide a high level of mechanical resistance and stress distribution.

HYTREL®

Exceptionally tough and elastic return: a high resistance to impact, flex fatigue and creep: excellent flexibility at low temperatures and at high temperatures it maintains most of its properties. It is also resistant to the attack of many industrial chemicals, oils and solvents.

SANTOPRENE®

Excellent resistance to acid and alkaline fluids, high flexural resistance and good abrasion resistance.



BOXER / CUBIC FAMILY

PTFE DIAPHRAGMS

This material is known for its considerable resistance to temperature and chemical and corrosive agents. Diaphragms in Debem PTFE undergo a double heat treatment to increase their elasticity and service life. A sample of each batch is subject to destructive tests to check their compliance with the technical requirements. This diaphragm can be installed combined with one of the ones examined earlier, in order to increase the resistance to the corrosive chemical agents and temperature of the fluid.



How does it work?

The compressed air introduced by the pneumatic exchanger (A) behind one of the two diaphragms generates the compression and pushes the product in the delivery duct (B) at the same time, the opposing diaphragms that

is integral with the exchanger shaft creates a vacuum and intakes the liquid (C). Once the stroke has been completed, the pneumatic exchanger diverts the compressed air behind the opposing diaphragm and the cycle is reversed.

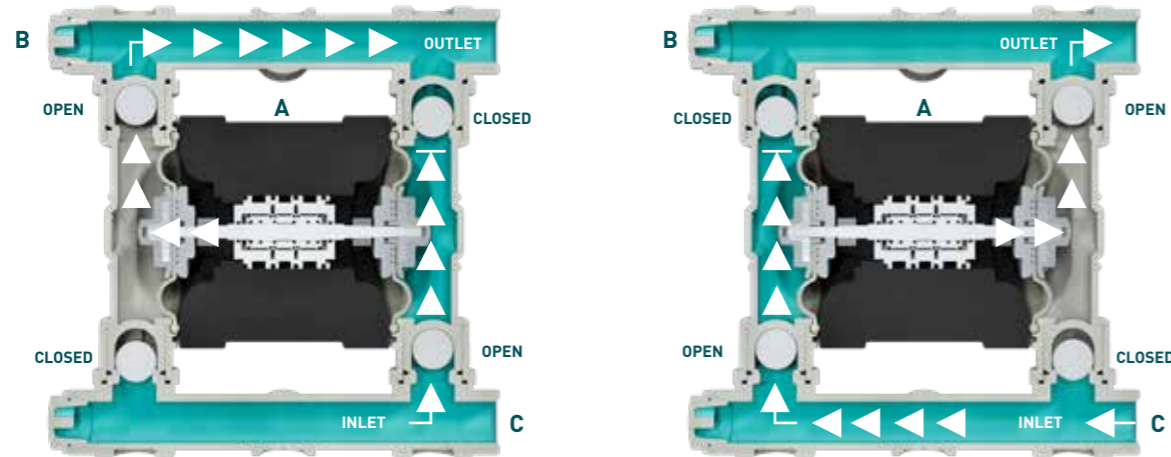

- 1 - o-ring
- 2 - cage
- 3 - ball
- 4 - ball seat
- 5 - cap
- 6 - fluid-side diaphragm
- 7 - air-side diaphragm
- 8 - central

- 9 - silencer filter
- 10 - cap
- 11 - vacuum manifold
- 12 - pump casing
- 13 - spacer
- 14 - Belleville washer
- 15 - cap
- 16 - delivery manifold

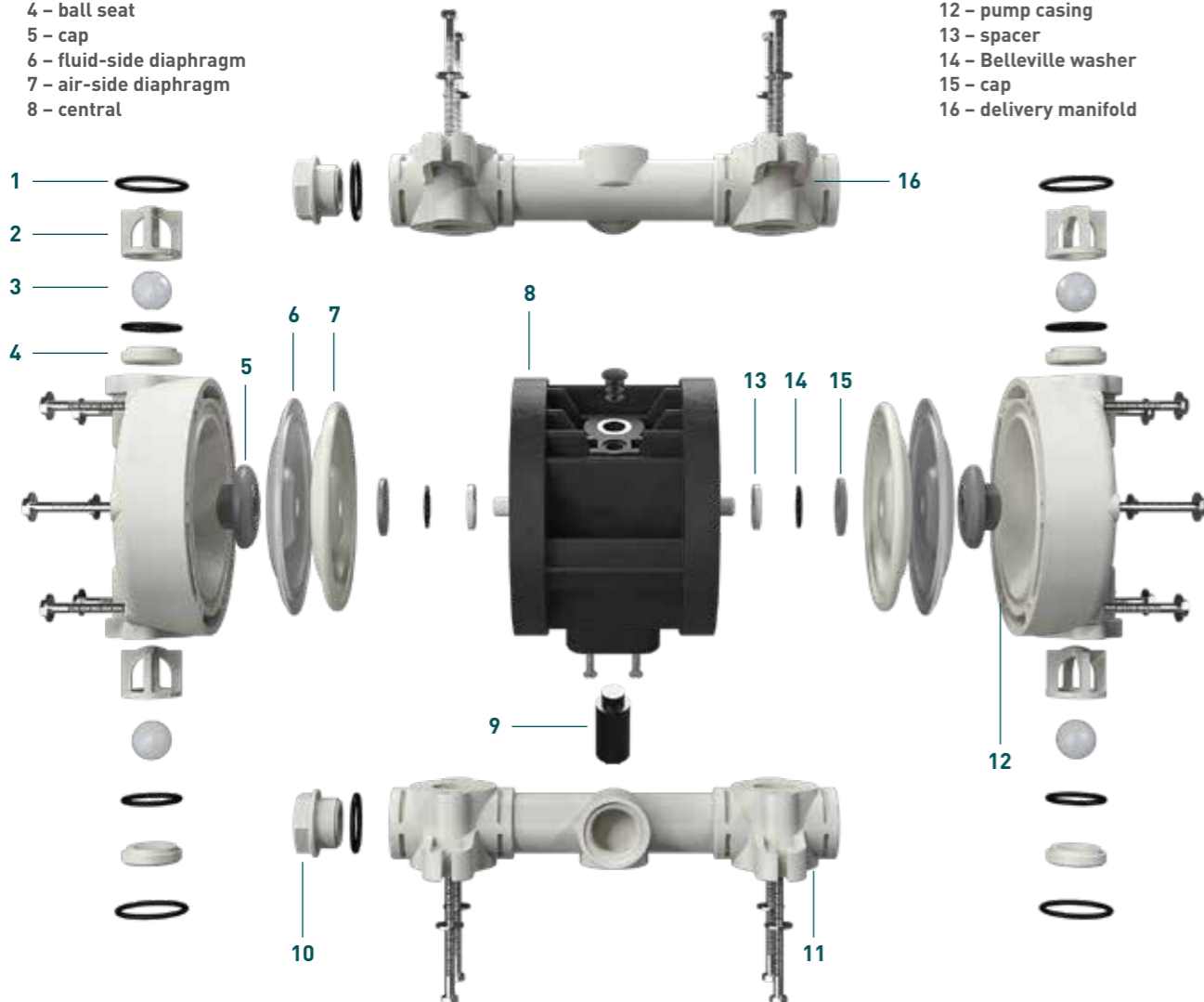

Installations



SELF-PRIMING

BOXER / CUBIC FAMILY



SPLIT SUCTION and DELIVERY

BOXER FAMILY



UNDER HEAD

BOXER / CUBIC FAMILY



SPLIT SUCTION

BOXER FAMILY

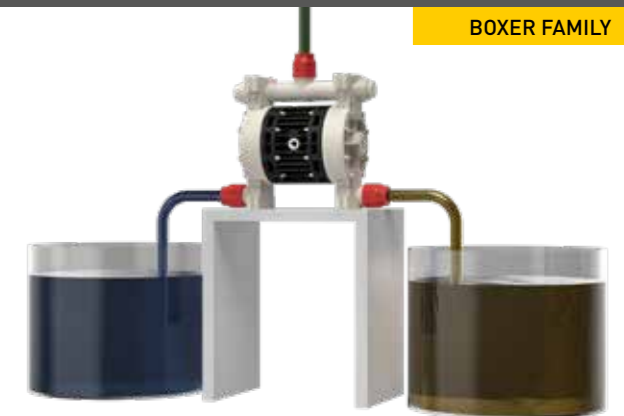

IMMERSED

BOXER / CUBIC FAMILY



DRUM TRANSFER

BOXER / CUBIC FAMILY





Debem's CUBIC diaphragm pumps are fitted with a centrally-positioned coaxial pneumatic motor.

The ATEX - IECEx certified air-operated double diaphragm pumps, with their unique design and limited size, are ideally suited to be installed directly on industrial equipment for the chemical sector, to pump ink and paint, on printing machines, in oil circulation and in applications where moderate quantities of fluid must be pumped in small spaces. The CUBIC range includes the MIDGETBOX pump which is currently the smallest and highest performing pump on the market for the chemical sector.

- Product designed and constructed in Italy
- PATENTED stall-prevention pneumatic circuit
- Operates with non-lubricated air
- Self-priming
- Dry operation
- ATEX certification for ZONE 1 - ZONE 2
- IECEx certification
- Adjustable operating speed
- Extremely versatile
- Suitable for pumping fluids in demanding applications
- Suitable for continuous use

CUBIC PUMPS CODES ENCODING

ex. ICU15P-NTTPV- - Internal distributor, Cubic 15, PP casing, NBR air side diaphragm, PTFE product side diaphragm, PTFE balls, PP ball seats, Viton® o-ring.

I	CU15	P	N	T	T	P	V	-	-
INTERNAL DISTRIBUTOR	PUMP MODEL	PUMP CASING	AIR-SIDE DIAPHRAGM	FLUID-SIDE DIAPHRAGM	BALLS	BALL SEATS	O-RING*	SPLIT MANIFOLD	CONDUCT VERSION
I	MID - Midgetbox (available only in PP/PP+CF) CU15 - Cubic 15	P - Polypropylene EC - ECTFE (Halar) PC - PP+CF	N - NBR	T - PTFE	G - Pyrex® A - AISI 316 T - PTFE	R - PPS-V K - PEEK' P - PP EC - ECTFE A - AISI 316 I - PE-UHMW	D - EPDM V - Viton® N - NBR T - PTFE	X Split manifold Y NPT thread J Spacer on shaft	C*

1) Only for MIDGETBOX

*C version CONDUCT for standard ATEX ZONE 1Ex II 2/2GD c IIB T135°C



A = ball valves
B = pumping chamber
C1 = product-side diaphragm
C2 = air-side diaphragm
D = pneumatic exchanger

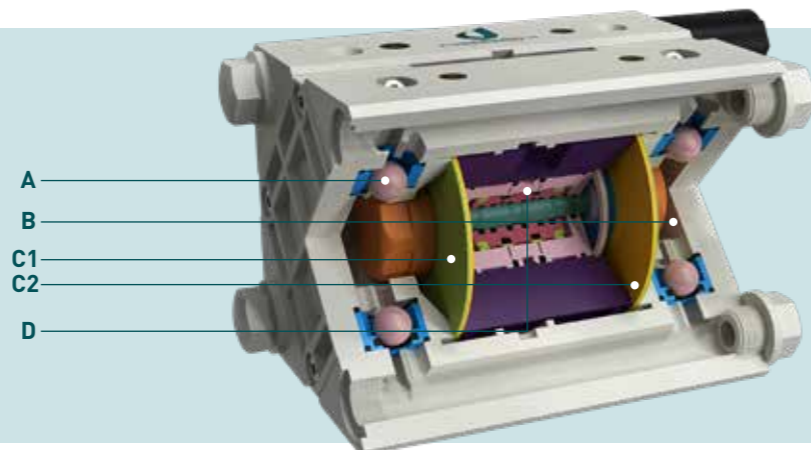

Specifications and types



Suction / delivery connections	G 1/4" f (*)
Air fitting	G 1/8" f
Max flow rate*	6 l/min
Max supply air pressure	8 bar
Max head*	80 m
Max negative suction head - dry-running**	3 m
Max negative suction head - pump primed	9.5 m
Max diameter of suspended solids	0 mm
Noise level	60 dB
Volume per stroke	3.2 cc

STANDARD: II 3G Ex h IIB T4 Gc - II 3D Ex h IIB T135°C Dc X
CONDUCT: II 2G Ex h IIB T4 Gb - II 2D Ex h IIB T135°C Db X

(*) Available with NPT connections (on request)

*The curves and performance are referred to pumps with submerged suction and a free delivery outlet with water at 20°C, and vary according to the construction material.
** The value depends on the configuration of the pump.



PP

Midgetbox



Maximum Dimensions

Height	75 mm
Width	121 mm
Depth	60 mm



Construction materials (casing and manifolds) and net weight

Polypropylene (with glass additive)	0.52 Kg
	Temp. 3°C min. 65°C max
Conductive polypropylene (with carbon additive)	0.52 Kg
	Temp. 3°C min. 65°C max

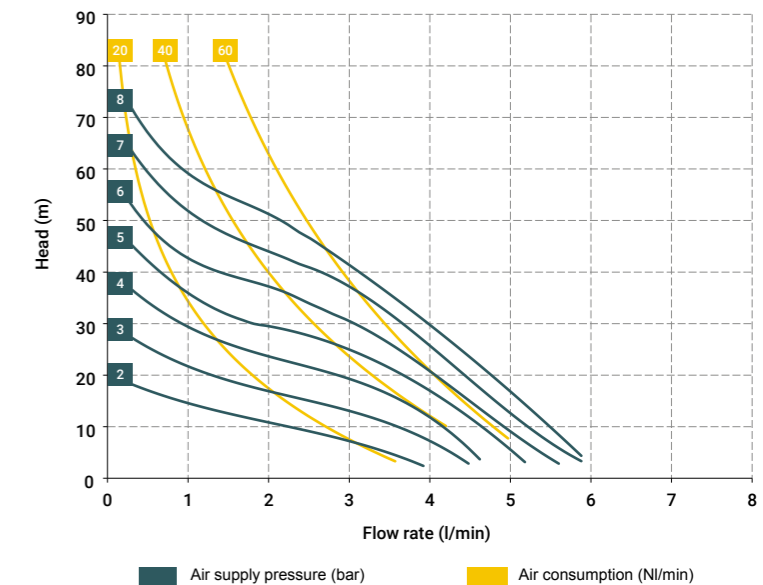

MAIN APPLICATION SECTORS



GRAPHIC INDUSTRY



WATER AND SLUDGE TREATMENT

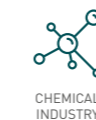

CHEMICAL INDUSTRY



GALVANIC AND ELECTRONIC INDUSTRY

Specifications and types

STANDARD: II 3G Ex h IIB T4 Gc - II 3D Ex h IIIB T135°C Dc X
 CONDUCT: II 2G Ex h IIb T4 Gb - II 2D Ex h IIIB T135°C Db X

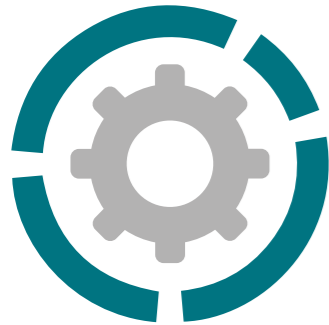

Suction / delivery connections	G 3/8" f (*)
Air fitting	G 3/8" f
Max flow rate*	17 l/min
Max supply air pressure	8 bar
Max head*	80 m
Max negative suction head - dry-running**	3 m
Max negative suction head - pump primed	9.5 m
Max diameter of suspended solids	0.5 mm
Noise level	65 dB
Volume per stroke	10.3 cc

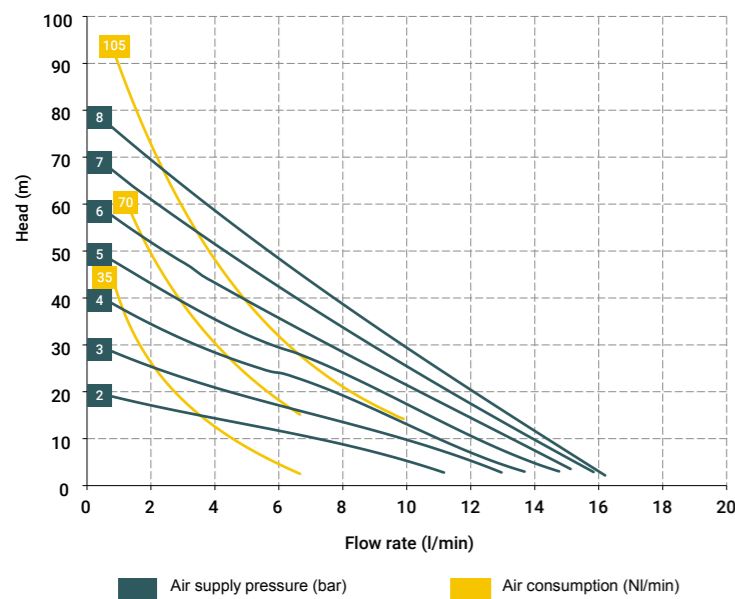

Cubic diaphragm pumps: high performance levels, excellent power and sturdiness, ideal for pumping liquids with high apparent viscosity, even if containing suspended solids. Particularly suited for small spaces.

[*] Available with NPT connections (on request)

*The curves and performance are referred to pumps with submerged suction and a free delivery outlet with water at 20°C, and vary according to the construction material.

** The value depends on the configuration of the pump.

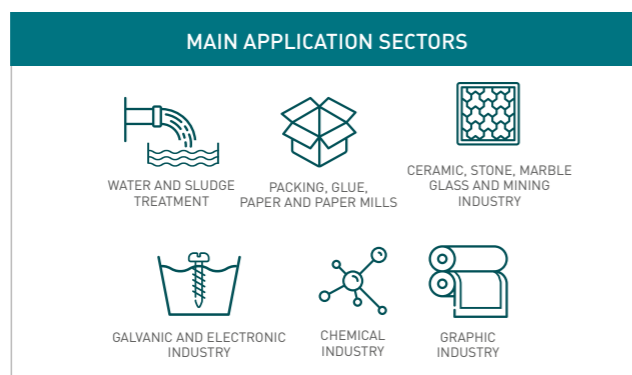

PP

Cubic 15



Maximum Dimensions	
Height	105 mm
Width	201 mm
Depth	105 mm

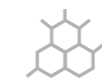

Construction materials (casing and manifolds) and net weight

Polypropylene (with glass additive)	1.35 Kg Temp. 3°C min. 65°C max
-------------------------------------	---------------------------------------

Conductive polypropylene (with carbon additive)	1.35 Kg Temp. 3°C min. 65°C max
---	---------------------------------------

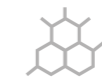

Construction materials (casing and manifolds) available on request

POMc	
UHMWPE	



ECTFE

Cubic 15



Maximum Dimensions	
Height	105 mm
Width	201 mm
Depth	105 mm

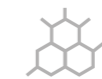

Construction materials (casing and manifolds) and net weight

ECTFE	1. Kg Temp. 3°C min. 95°C max
-------	-------------------------------------

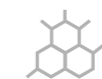

Construction materials (casing and manifolds) available on request

POMc	
UHMWPE	

Air-operated double diaphragm volumetric pumps, ATEX – IECEx certified, constructed in polypropylene or PVDF in the plastic version or in aluminium or AISI 316 L for the metal versions. BOXER pumps are ideal for pumping liquids with high apparent viscosity, even if containing suspended solids. The vast range of materials available for the parts in contact with the flu-

id, such as pump casings and manifolds, diaphragms, balls, ball seats and o-rings, makes them compatible with any type of fluid present on the market. They can be used in numerous applications such as the following industries: chemical, graphic, paint, galvanic, ceramic, naval, textile, leather, mechanical, oil and many more.

- **Product designed and constructed in Italy**
- **PATENTED stall-prevention pneumatic circuit**
- **Operates with non-lubricated air**
- **Self-priming**
- **Dry operation**
- **ATEX certification for ZONE 1 - ZONE 2**
- **IECEx certification**
- **Adjustable operating speed**
- **Extremely versatile**
- **Suitable for pumping liquids with high viscosity and demanding applications**
- **Possibility of pumping fluids containing suspended solids**
- **Possibility of suspended installation**
- **Manifolds can be supplied with stainless steel reinforcement rings for pumps in PP – PP+CF – PVDF**
- **Nozzles available with clamp connections and DIN 11851 (only pumps in AISI 316)**
- **LONG LIFE profile diaphragms (available in different elastomers) for greater resistance and longer life**
- **Suitable for continuous use**

BOXER PUMPS CODES ENCODING

ex. IB50-P-HTTPV--
Internal distributor, Boxer 50, PP casing, Hytrel® air side diaphragm, PTFE product side diaphragm, PTFE balls, PP ball seats, Viton® o-ring.

I	B50-	P	H	T	T	P	V	-	-
INTERNAL DISTRIBUTOR	PUMP MODEL	PUMP CASING	AIR-SIDE DIAPHRAGM	FLUID-SIDE DIAPHRAGM	BALLS	BALL SEATS	O-RING	SPLIT MANIFOLD	CONDUCT VERSION
I	B7 Boxer 7 B15 Boxer 15 MICR Microboxer MIN Miniboxer B35 Boxer 35 B50 Boxer 50 B81 Boxer 81 B90 Boxer90 B100 Boxer 100 B150 Boxer 150 B251 Boxer 251 B252 Boxer 252 B502 Boxer 502 B522 Boxer 522 B503 Boxer 503	P - Polypropylene FC - PVDF+CF PC - PP+CF AL - Aluminium A - AISI 316	N - NBR D - EPDM H - Hytrel M - Santoprene	T - PTFE	T - PTFE A - AISI 316 D - EPDM N - NBR	P - Polypropylene F - PVDF A - AISI 316 I - PE-UHMW R - PPS-V L - Aluminium	D - EPDM V - Viton® N - NBR T - PTFE S - Silicone	X* 3* Y* J* W*	C* Z*

*X = split manifold
*3 = 3° central hole on manifold
*Y = "NPT" thread
*J = spacer on shaft
*W = clamp manifold (all only on request)

C = version CONDUCT for standard ATEX ZONE 1 Ex II 2/2GD c IIB T135°C
Z = version for standard IECEx (both only on request)



Specifications and types



Suction / delivery connections	G 1/4" f (*)
Air fitting	G 1/8" f
Max flow rate*	9 l/min
Max supply air pressure	8 bar
Max head*	80 m
Max negative suction head - dry-running**	4 m
Max negative suction head - pump primed	9.5 m
Max diameter of suspended solids	0.5 mm
Noise level	65 dB
Volume per stroke	3.2 cc

STANDARD: II 3G Ex h IIB T4 Gc - II 3D Ex h IIB T135°C Dc X - I M2 Ex h I Mb X
CONDUCT: II 2G Ex h IIB T4 Gb - II 2D Ex h IIB T135°C Db X - Ex h IIB T4 Gb - Ex h IIB T135°C Db



PP Boxer 7

Maximum Dimensions	
Height	120 mm
Width	138 mm
Depth	68 mm

Construction materials (casing and manifolds) and net weight	
Polypropylene (with glass additive)	0.7 Kg Temp. 3°C min. 65°C max
Conductive polypropylene (with carbon additive)	- Temp. 3°C min. 65°C max

PVDF Boxer 7

Maximum Dimensions	
Height	120 mm
Width	138 mm
Depth	68 mm

Construction materials (casing and manifolds) and net weight	
PVDF	- Temp. 3°C min. 95°C max

(*) Available with NPT connections (on request)

*The curves and performance are referred to pumps with submerged suction and a free delivery outlet with water at 20°C, and vary according to the construction material.
** The value depends on the configuration of the pump.

MAIN APPLICATION SECTORS

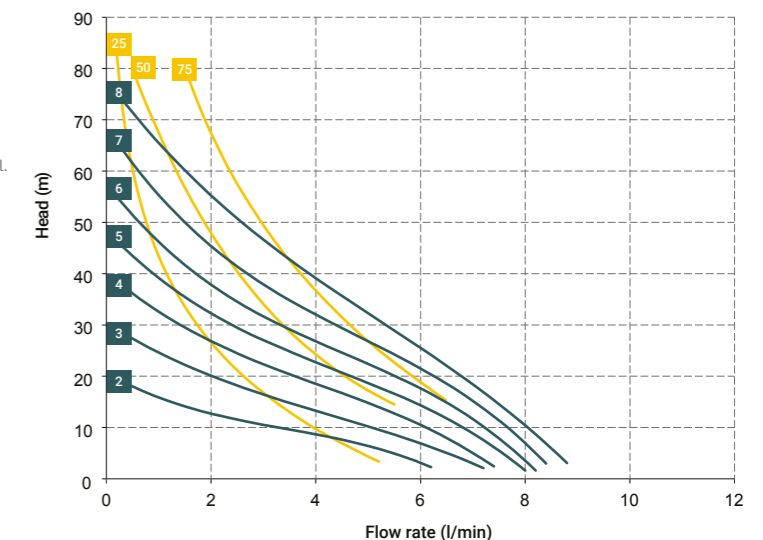

Specifications and types

STANDARD: II 3G Ex h IIB T4 Gc - II 3D Ex h IIIB T135°C Dc X - I M2 Ex h I Mb X
 CONDUCT: II 2G Ex h IIB T4 Gb - II 2D Ex h IIIB T135°C Db X - Ex h IIB T4 Gb - Ex h IIIB T135°C Db

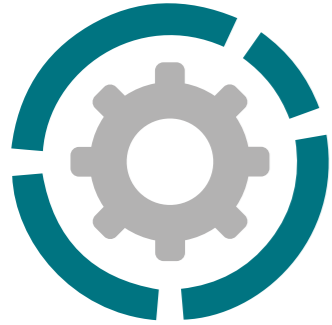

Suction / delivery connections	G 3/8" f (*)
Air fitting	G 3/8" f
Max flow rate*	17 l/min
Max supply air pressure	8 bar
Max head*	80 m
Max negative suction head - dry-running**	3 m
Max negative suction head - pump primed	9.5 m
Max diameter of suspended solids	0.5 mm
Noise level	65 dB
Volume per stroke	10.3 cc

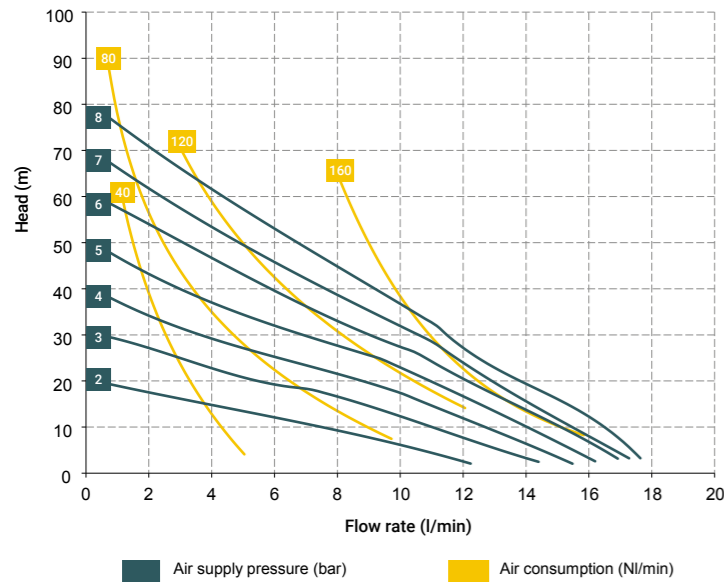

MAIN APPLICATION SECTORS



(*) Available with Clamp or NPT connections (only on request)
 *The curves and performance are referred to pumps with submerged suction and a free delivery outlet with water at 20°C, and vary according to the construction material.
 ** The value depends on the configuration of the pump.



PVDF Boxer 15

Maximum Dimensions	
Height	151 mm
Width	148 mm
Depth	80 mm
Construction materials (casing and manifolds) and net weight	
PVDF	1.38 Kg Max 3°C min. 95°C max
Construction materials (casing and manifolds) available on request	
POMc	
UHMWPE	



ALU Boxer 15

Maximum Dimensions	
Height	141 mm
Width	153 mm
Depth	80 mm
Construction materials (casing and manifolds) and net weight	
ALU	1.9 Kg Max 3°C min. 95°C max



PP Boxer 15

Maximum Dimensions	
Height	151 mm
Width	148 mm
Depth	80 mm
Construction materials (casing and manifolds) and net weight	
Polypropylene (with glass additive)	1.1 Kg Max 3°C min. 65°C max
Conductive polypropylene (with carbon additive)	1.1 Kg Max 3°C min. 65°C max
Construction materials (casing and manifolds) available on request	
POMc	
UHMWPE	



AISI 316 L steel Boxer 15

Maximum Dimensions	
Height	141 mm
Width	153 mm
Depth	80 mm
Construction materials (casing and manifolds) and net weight	
AISI 316 L	2.4 Kg Max 3°C min. 95°C max
Construction materials (casing and manifolds) available on request	
DUPLEX/W.DUPLEX	

Specifications and types

STANDARD: II 3G Ex h IIB T4 Gc - II 3D Ex h IIIB T135°C Dc X - I M2 Ex h I Mb X
 CONDUCT: II 2G Ex h IIB T4 Gb - II 2D Ex h IIIB T135°C Db X - Ex h IIB T4 Gb - Ex h IIIB T135°C Db

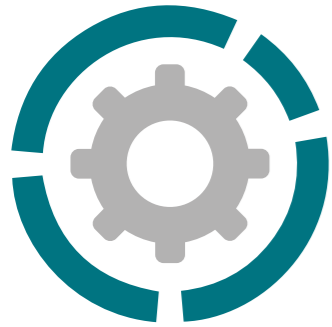

Suction / delivery connections	G 1/2" f (*)
Air fitting	G 1/4" f
Max flow rate*	35 l/min
Max supply air pressure	8 bar
Max head*	80 m
Max negative suction head - dry-running**	4 m
Max negative suction head - pump primed	9.5 m
Max diameter of suspended solids	2 mm
Noise level	65 dB
Volume per stroke	30 cc

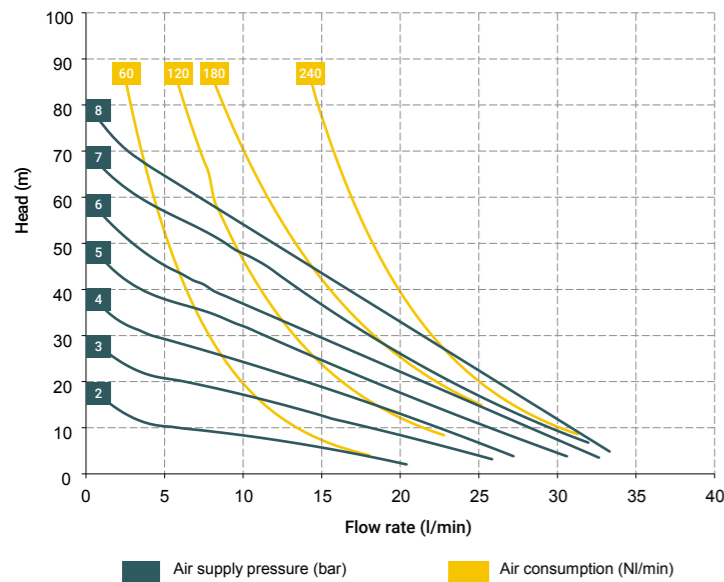

MAIN APPLICATION SECTORS

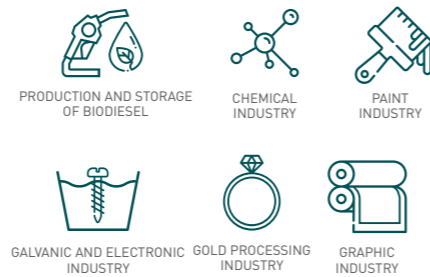

(*) Available with Clamp or NPT connections (only on request)

*The curves and performance are referred to pumps with submerged suction and a free delivery outlet with water at 20°C, and vary according to the construction material.
 ** The value depends on the configuration of the pump.



PVDF Microboxer

Maximum Dimensions	
Height	168 mm
Width	165 mm
Depth	120 mm
Construction materials (casing and manifolds) and net weight	
PVDF	1.98 Kg Max 3°C min. 95°C max
Construction materials (casing and manifolds) available on request	
POMc	
UHMWPE	



ALU Microboxer

Maximum Dimensions	
Height	172 mm
Width	164 mm
Depth	120 mm
Construction materials (casing and manifolds) and net weight	
ALU	2.1 Kg Max 3°C min. 95°C max



PP Microboxer

Maximum Dimensions	
Height	168 mm
Width	165 mm
Depth	120 mm
Construction materials (casing and manifolds) and net weight	
Polypropylene (with glass additive)	1.6 Kg Max 3°C min. 65°C max
Conductive polypropylene (with carbon additive)	1.6 Kg Max 3°C min. 65°C max
Construction materials (casing and manifolds) available on request	
POMc	
UHMWPE	



AISI 316 L steel Microboxer

Maximum Dimensions	
Height	171 mm
Width	177 mm
Depth	120 mm
Construction materials (casing and manifolds) and net weight	
AISI 316 L	3.75 Kg Max 3°C min. 95°C max
Construction materials (casing and manifolds) available on request	
DUPLEX/W.DUPLEX	

BOXER 50 / MINIBOXER



Specifications and types

STANDARD: II 3G Ex h IIB T4 Gc - II 3D Ex h IIIB T135°C Dc X - I M2 Ex h I Mb X
 CONDUCT: II 2G Ex h IIb T4 Gb - II 2D Ex h IIIB T135°C Db X - Ex h IIB T4 Gb - Ex h IIIB T135°C Db

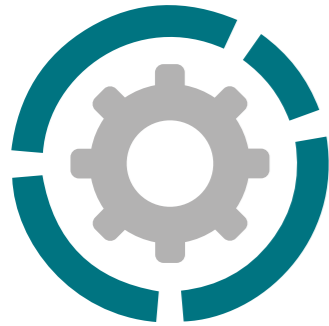

Suction / delivery connections	G 1/2" or DN 15 (*)
Air fitting	G 3/8" f
Max flow rate*	60 l/min
Max supply air pressure	8 bar
Max head*	80 m
Max negative suction head - dry-running**	4 m
Max negative suction head - pump primed	9.5 m
Max diameter of suspended solids	4 mm
Noise level	70 dB
Volume per stroke	67 cc

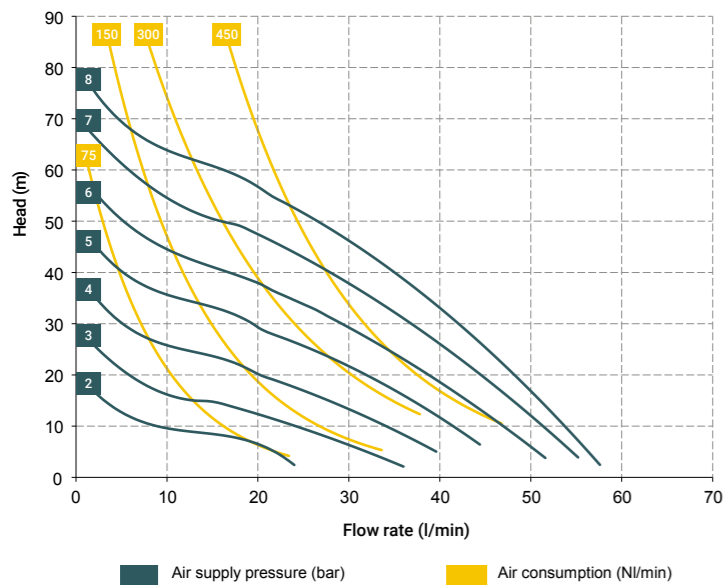

MAIN APPLICATION SECTORS

AUTOMOTIVE	PRODUCTION AND STORAGE OF BIODIESEL	PAINT INDUSTRY	CHEMICAL INDUSTRY
GRAPHIC OIL & GAS	CERAMIC, STONE, MARBLE, GLASS AND MINING INDUSTRY	GALVANIC AND ELECTRONIC INDUSTRY	INDUSTRY
GOLD PROCESSING INDUSTRY	MECHANICAL AND METALLURGIC INDUSTRY	PACKING, GLUE, PAPER AND PAPER MILLS	

Legend: ● BOXER 50 ● MINIBOXER

(*) Available with NPT connections (on request)

*The curves and performance are referred to pumps with submerged suction and a free delivery outlet with water at 20°C, and vary according to the construction material.
 ** The value depends on the configuration of the pump.



PVDF Boxer 50

	Maximum Dimensions	
	Height	241 mm
	Width	247 mm
	Depth	153 mm
	Construction materials (casing and manifolds) and net weight	
	PVDF	4.25 Kg Max 3°C min. 95°C max
	Construction materials (casing and manifolds) available on request	
	POMc	
	UHMWPE	



ALU Boxer 50

	Maximum Dimensions	
	Height	234 mm
	Width	241 mm
	Depth	153 mm
	Construction materials (casing and manifolds) and net weight	
	ALU	4.07 Kg Max 3°C min. 95°C max



PP Boxer 50

	Maximum Dimensions	
	Height	241 mm
	Width	247 mm
	Depth	153 mm
	Construction materials (casing and manifolds) and net weight	
	Polypropylene (with glass additive)	3.75 Kg Max 3°C min. 65°C max
	Conductive polypropylene (with carbon additive)	3.75 Kg Max 3°C min. 65°C max
	Construction materials (casing and manifolds) available on request	
	POMc	
	UHMWPE	



MINIBOXER

AISI 316 L steel

	Maximum Dimensions	
	Height	232 mm
	Width	230 mm
	Depth	153 mm
	Construction materials (casing and manifolds) and net weight	
	AISI 316 L	6.3 Kg Max 3°C min. 95°C max
	Construction materials (casing and manifolds) available on request	
	DUPLEX/W.DUPLEX	

BOXER 81 / BOXER 90



Specifications and types

STANDARD: II 3G Ex h IIB T4 Gc - II 3D Ex h IIIB T135°C Dc X - I M2 Ex h I Mb X
 CONDUCT: II 2G Ex h IIB T4 Gb - II 2D Ex h IIIB T135°C Db X - Ex h IIB T4 Gb - Ex h IIIB T135°C Db

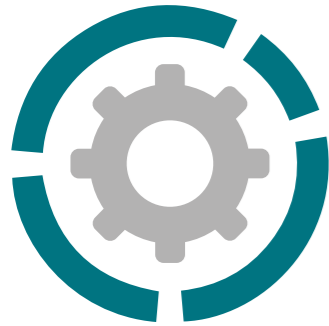

Suction / delivery connections	G 1" or DN 25 (*)
Air fitting	G 3/8" f
Max flow rate*	110 l/min
Max supply air pressure	8 bar
Max head*	80 m
Max negative suction head - dry-running**	4 m
Max negative suction head - pump primed	9,5 m
Max diameter of suspended solids	4 mm
Noise level	70 dB
Volume per stroke	100 cc

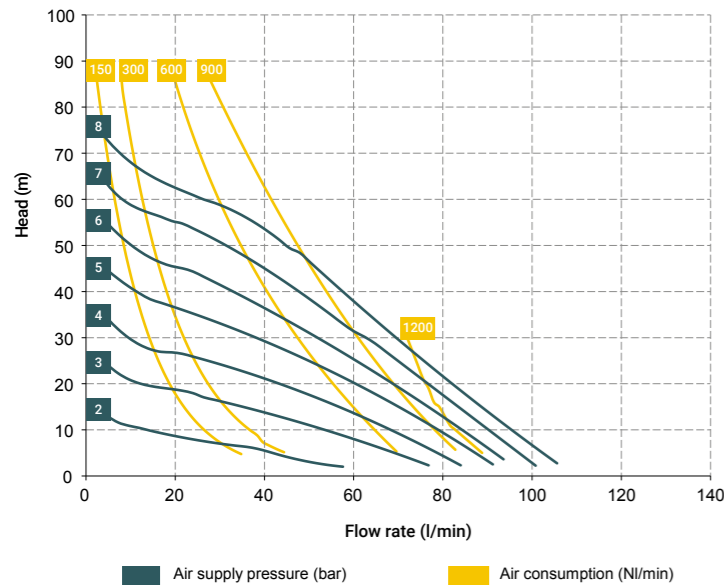

MAIN APPLICATION SECTORS



PVDF

Boxer 81



Maximum Dimensions

Height	274 mm
Width	308 mm
Depth	170 mm



Construction materials (casing and manifolds) and net weight

PVDF	6 Kg
	Max 3°C min.
	95°C max



Construction materials (casing and manifolds) available on request

POMc

UHMWPE



Electropolished AISI 316 steel

Boxer 81



Maximum Dimensions

Height	275 mm
Width	305 mm
Depth	170 mm



Construction materials (casing and manifolds) and net weight

Electropolished AISI 316	10.6 Kg
	Max 3°C min.
	95°C max



Construction materials (casing and manifolds) available on request

DUPLEX/W.DUPLEX

(*) Available with NPT connections (on request)

*The curves and performance are referred to pumps with submerged suction and a free delivery outlet with water at 20°C, and vary according to the construction material.

** The value depends on the configuration of the pump.



PP

Boxer 81



Maximum Dimensions

Height	274 mm
Width	308 mm
Depth	170 mm



Construction materials (casing and manifolds) and net weight

Polypropylene (with glass additive)	5 Kg
	Max 3°C min.
	65°C max



Conductive polypropylene (with carbon additive)	5 Kg
	Max 3°C min.
	65°C max

Construction materials (casing and manifolds) available on request

POMc

UHMWPE



BOXER 90

ALU



Maximum Dimensions

Height	291 mm
Width	293 mm
Depth	170 mm



Construction materials (casing and manifolds) and net weight

ALU	7 Kg
	Max 3°C min.
	95°C max

Specifications and types

STANDARD: II 3G Ex h IIB T4 Gc - II 3D Ex h IIIB T135°C Dc X - I M2 Ex h I Mb X
 CONDUCT: II 2G Ex h IIB T4 Gb - II 2D Ex h IIIB T135°C Db X - Ex h IIB T4 Gb - Ex h IIIB T135°C Db

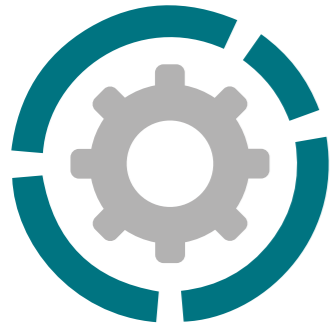

Suction / delivery connections	G 1" or DN 25 (*)
Air fitting	G 3/8" f
Max flow rate*	160 l/min
Max supply air pressure	8 bar
Max head*	80 m
Max negative suction head - dry-running**	4 m
Max negative suction head - pump primed	9.5 m
Max diameter of suspended solids	4 mm
Noise level	75 dB
Volume per stroke	222 cc

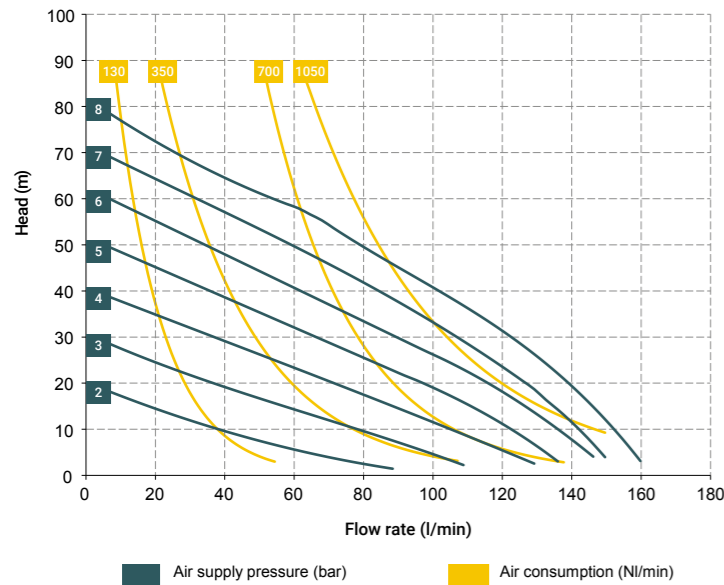

(*) Available with NPT connections (on request)

*The curves and performance are referred to pumps with submerged suction and a free delivery outlet with water at 20°C, and vary according to the construction material.
 ** The value depends on the configuration of the pump.

MAIN APPLICATION SECTORS



PVDF Boxer 100

Maximum Dimensions	
Height	325 mm
Width	329 mm
Depth	202 mm
Construction materials (casing and manifolds) and net weight	
PVDF	9.6 Kg Max 3°C min. 95°C max
Construction materials (casing and manifolds) available on request	
POMc	
UHMWPE	



ALU Boxer 100

Maximum Dimensions	
Height	324 mm
Width	315 mm
Depth	202 mm
Construction materials (casing and manifolds) and net weight	
ALU	8.5 Kg Max 3°C min. 95°C max



PP Boxer 100

Maximum Dimensions	
Height	325 mm
Width	329 mm
Depth	202 mm
Construction materials (casing and manifolds) and net weight	
Polypropylene (with glass additive)	7.6 Kg Max 3°C min. 65°C max
Conductive polypropylene (with carbon additive)	7.6 Kg Max 3°C min. 65°C max
Construction materials (casing and manifolds) available on request	
POMc	
UHMWPE	



Electropolished AISI 316 steel Boxer 100

Maximum Dimensions	
Height	327 mm
Width	308 mm
Depth	202 mm
Construction materials (casing and manifolds) and net weight	
Electropolished AISI 316	11.7 Kg Max 3°C min. 95°C max
Construction materials (casing and manifolds) available on request	
DUPLEX/W.DUPLEX	

Specifications and types

STANDARD: II 3G Ex h IIB T4 Gc - II 3D Ex h IIIB T135°C Dc X - I M2 Ex h I Mb X
 CONDUCT: II 2G Ex h IIB T4 Gb - II 2D Ex h IIIB T135°C Db X - Ex h IIB T4 Gb - Ex h IIIB T135°C Db



Suction / delivery connections	G 1 1/4 or DN 32 (*)
Air fitting	G 1/2" f
Max flow rate*	220 l/min
Max supply air pressure	8 bar
Max head*	80 m
Max negative suction head - dry-running**	4 m
Max negative suction head - pump primed	9.5 m
Max diameter of suspended solids	5 mm
Noise level	75 dB
Volume per stroke	340 cc

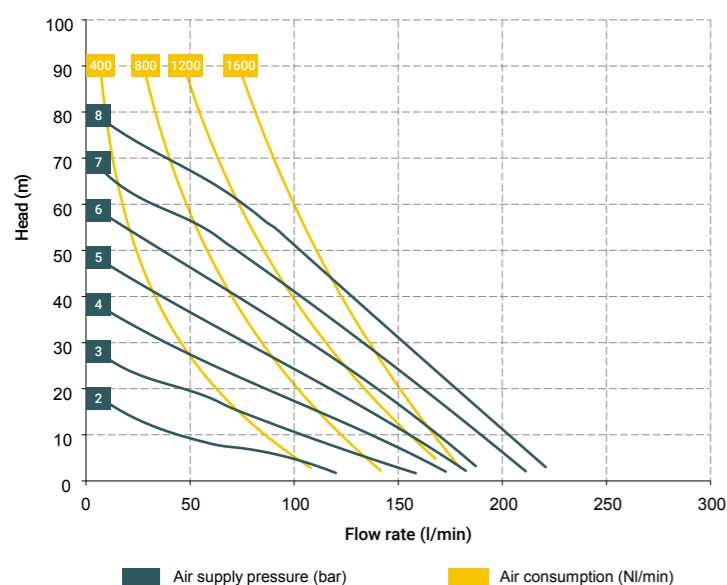

MAIN APPLICATION SECTORS



(*) Available with Clamp or NPT connections (only on request)

*The curves and performance are referred to pumps with submerged suction and a free delivery outlet with water at 20°C, and vary according to the construction material.
 ** The value depends on the configuration of the pump.



PVDF Boxer 150

Maximum Dimensions	
Height	386 mm
Width	399 mm
Depth	220 mm
Construction materials (casing and manifolds) and net weight	
PVDF	14 Kg Max 3°C min. 95°C max
Construction materials (casing and manifolds) available on request	
POMc	
UHMWPE	



ALU Boxer 150

Maximum Dimensions	
Height	388 mm
Width	394 mm
Depth	220 mm
Construction materials (casing and manifolds) and net weight	
ALU	15 Kg Max 3°C min. 95°C max



PP Boxer 150

Maximum Dimensions	
Height	386 mm
Width	399 mm
Depth	220 mm
Construction materials (casing and manifolds) and net weight	
Polypropylene (with glass additive)	12 Kg Max 3°C min. 65°C max
Conductive polypropylene (with carbon additive)	12 Kg Max 3°C min. 65°C max
Construction materials (casing and manifolds) available on request	
POMc	
UHMWPE	



Electropolished AISI 316 steel Boxer 150

Maximum Dimensions	
Height	390 mm
Width	388 mm
Depth	220 mm
Construction materials (casing and manifolds) and net weight	
Electropolished AISI 316	23 Kg Max 3°C min. 95°C max
Construction materials (casing and manifolds) available on request	
DUPLEX/W.DUPLEX	

BOXER 251 / BOXER 252

Specifications and types

STANDARD: II 3G Ex h IIB T4 Gc - II 3D Ex h IIIB T135°C Dc X - I M2 Ex h I Mb X
 CONDUCT: II 2G Ex h IIB T4 Gb - II 2D Ex h IIIB T135°C Db X - Ex h IIB T4 Gb - Ex h IIIB T135°C Db

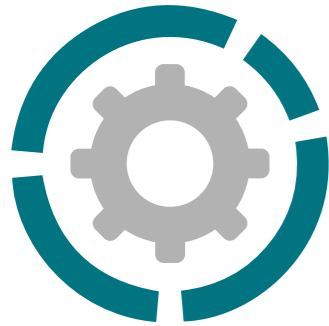

Suction / delivery connections	G 1 1/2" f or DN 40 (*)
Air fitting	G 1/2" f
Max flow rate*	340 l/min
Max supply air pressure	8 bar
Max head*	80 m
Max negative suction head - dry-running**	4 m
Max negative suction head - pump primed	9.5 m
Max diameter of suspended solids	6 mm
Noise level	80 dB
Volume per stroke	552 cc

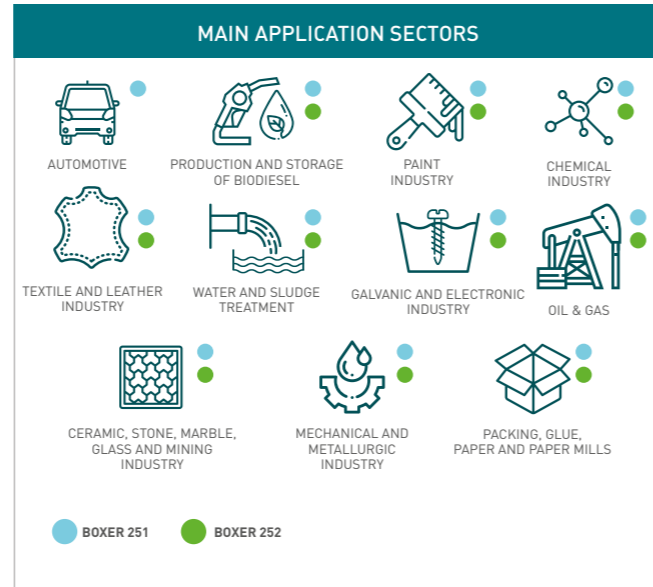
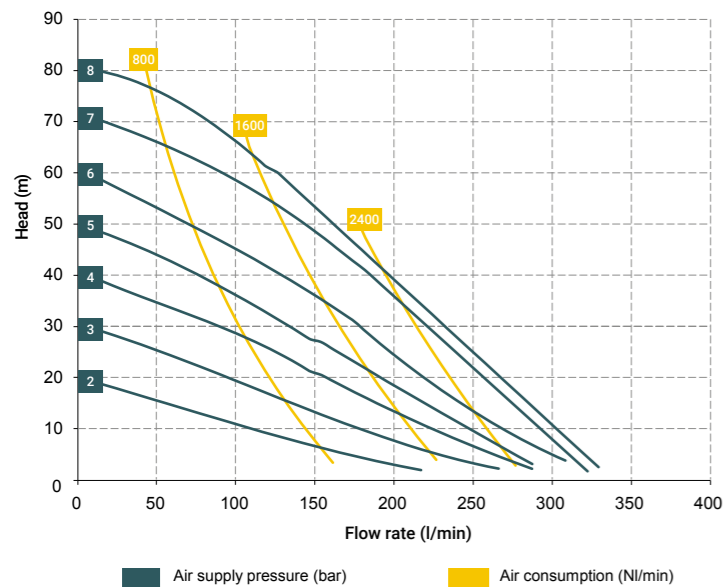

PVDF Boxer 251

Maximum Dimensions	
Height	492 mm
Width	493 mm
Depth	254 mm
Construction materials (casing and manifolds) and net weight	
PVDF	20 Kg Max 3°C min. 95°C max



ALU Boxer 251

Maximum Dimensions	
Height	491 mm
Width	490 mm
Depth	254 mm
Construction materials (casing and manifolds) and net weight	
ALU	19 Kg Max 3°C min. 95°C max

(*) Available with NPT connections (on request)
 *The curves and performance are referred to pumps with submerged suction and a free delivery outlet with water at 20°C, and vary according to the construction material.
 ** The value depends on the configuration of the pump.



PP Boxer 251

Maximum Dimensions	
Height	492 mm
Width	493 mm
Depth	254 mm
Construction materials (casing and manifolds) and net weight	
Polypropylene (with glass additive)	17.5 Kg Max 3°C min. 65°C max
Conductive polypropylene (with carbon additive)	20 Kg Max 3°C min. 65°C max



BOXER 252 Electropolished AISI 316 steel

Maximum Dimensions	
Height	538 mm
Width	417 mm
Depth	254 mm
Construction materials (casing and manifolds) and net weight	
Electropolished AISI 316	26.2 Kg Max 3°C min. 95°C max
Construction materials (casing and manifolds) available on request	
DUPLEX/W.DUPLEX	

BOXER 522 / BOXER 502



Specifications and types

STANDARD: II 3G Ex h IIB T4 Gc - II 3D Ex h IIIB T135°C Dc X - I M2 Ex h I Mb X
 CONDUCT: II 2G Ex h IIB T4 Gb - II 2D Ex h IIIB T135°C Db X - Ex h IIB T4 Gb - Ex h IIIB T135°C Db

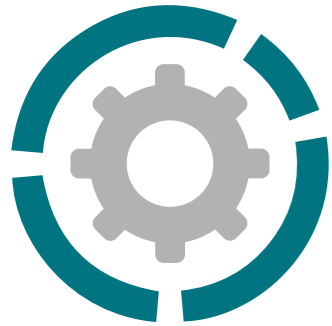

Suction / delivery connections	G 2" f or DN 50 (*)
Air fitting	G 1/2" f
Max flow rate*	600 l/min
Max supply air pressure	8 bar
Max head*	80 m
Max negative suction head - dry-running**	5 m
Max negative suction head - pump primed	9.5 m
Max diameter of suspended solids	8 mm
Noise level	80 dB
Volume per stroke	1825 cc

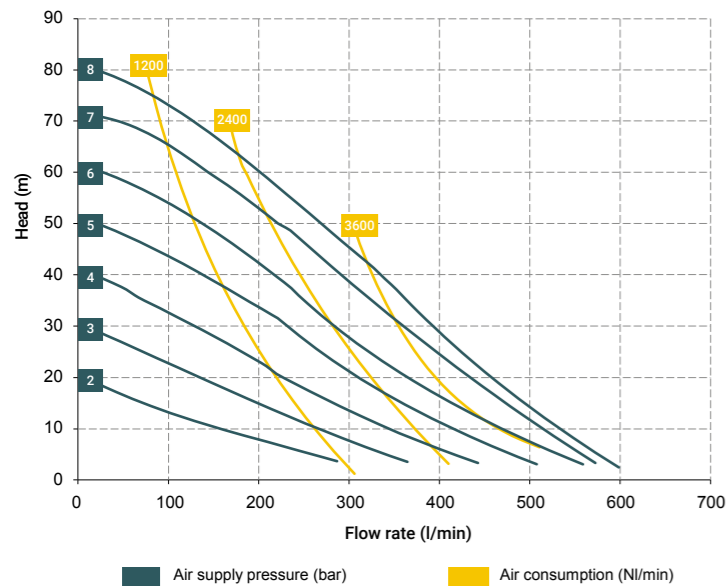

MAIN APPLICATION SECTORS

- TEXTILE AND LEATHER INDUSTRY
- PRODUCTION AND STORAGE OF BIODIESEL
- PAINT INDUSTRY
- CHEMICAL INDUSTRY
- CERAMIC, STONE, MARBLE, GLASS AND MINING INDUSTRY
- WATER AND SLUDGE TREATMENT
- GALVANIC AND ELECTRONIC INDUSTRY
- OIL & GAS
- MECHANICAL AND METALLURGIC INDUSTRY
- PACKING, GLUE, PAPER AND PAPER MILLS

Legend: ● BOXER 522 ● BOXER 502



PVDF

Boxer 522



Maximum Dimensions

Height	650 mm
Width	590 mm
Depth	404 mm



Construction materials (casing and manifolds) and net weight

PVDF	45 Kg Max 3°C min. 95°C max
------	-----------------------------------



BOXER 502

ALU



Maximum Dimensions

Height	621 mm
Width	566 mm
Depth	404 mm



Construction materials (casing and manifolds) and net weight

ALU	37 Kg Max 3°C min. 95°C max
-----	-----------------------------------

(*) Available with NPT connections (on request)

*The curves and performance are referred to pumps with submerged suction and a free delivery outlet with water at 20°C, and vary according to the construction material.
 ** The value depends on the configuration of the pump.



PP

Boxer 522



Maximum Dimensions

Height	650 mm
Width	590 mm
Depth	404 mm



Construction materials (casing and manifolds) and net weight

Polypropylene (with glass additive)	38 Kg Max 3°C min. 65°C max
Conductive polypropylene (with carbon additive)	34.5 Kg Max 3°C min. 65°C max



BOXER 502

Electropolished AISI 316 steel



Maximum Dimensions

Height	705 mm
Width	470 mm
Depth	404 mm



Construction materials (casing and manifolds) and net weight

Electropolished AISI 316	54 Kg Max 3°C min. 95°C max
--------------------------	-----------------------------------



Construction materials (casing and manifolds) available on request DUPLEX/W.DUPLEX

Specifications and types

STANDARD: II 3G Ex h IIB T4 Gc - II 3D Ex h IIIB T135°C Dc X - I M2 Ex h I Mb X
 CONDUCT: II 2G Ex h IIB T4 Gb - II 2D Ex h IIIB T135°C Db X - Ex h IIB T4 Gb - Ex h IIIB T135°C Db

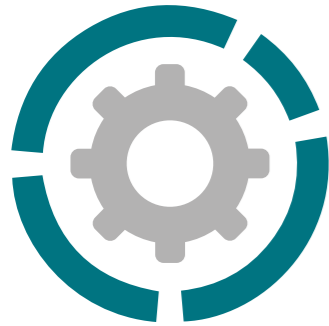

Suction / delivery connections	G 3" f or DN 80 (*)
Air fitting	G 3/4" f
Max flow rate*	800 l/min
Max supply air pressure	8 bar
Max head*	80 m
Max negative suction head - dry-running**	4 m
Max negative suction head - pump primed	9.5 m
Max diameter of suspended solids	10 mm
Noise level	80 dB
Volume per stroke	1825 cc

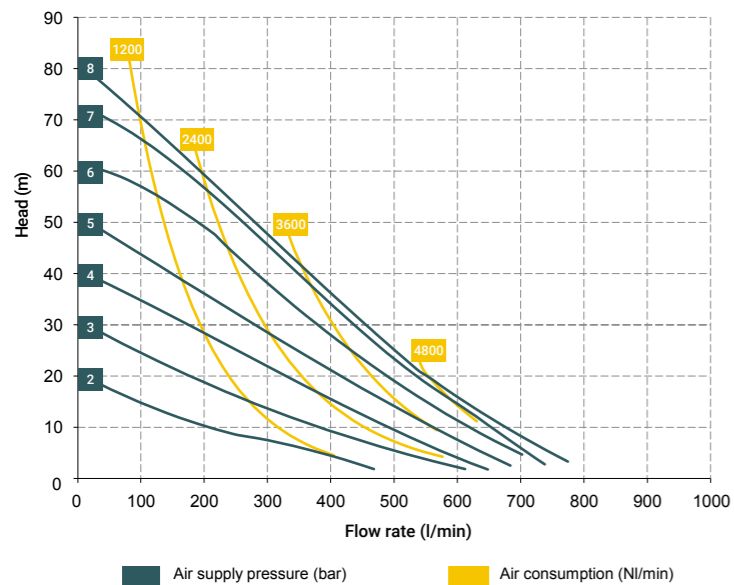

MAIN APPLICATION SECTORS

- TEXTILE AND LEATHER INDUSTRY
- PRODUCTION AND STORAGE OF BIODIESEL
- PAINT INDUSTRY
- CERAMIC, STONE, MARBLE, GLASS AND MINING INDUSTRY
- WATER AND SLUDGE TREATMENT
- PACKING, GLUE, PAPER AND PAPER MILLS
- CHEMICAL INDUSTRY
- MECHANICAL AND METALLURGIC INDUSTRY
- OIL & GAS



PVDF Boxer 503



Maximum Dimensions	
Height	726 mm
Width	585 mm
Depth	403 mm



Construction materials (casing and manifolds) and net weight	
PVDF	67 Kg Max 3°C min. 95°C max



ALU Boxer 503



Maximum Dimensions	
Height	806 mm
Width	580 mm
Depth	404 mm



Construction materials (casing and manifolds) and net weight	
ALU	66 Kg Max 3°C min. 95°C max



PP Boxer 503



Maximum Dimensions	
Height	726 mm
Width	585 mm
Depth	403 mm



Construction materials (casing and manifolds) and net weight	
Polypropylene (with glass additive)	50 Kg Max 3°C min. 65°C max
Conductive polypropylene (with carbon additive)	50 Kg Max 3°C min. 65°C max



Electropolished AISI 316 steel Boxer 503



Maximum Dimensions	
Height	826 mm
Width	546 mm
Depth	404 mm



Construction materials (casing and manifolds) and net weight	
Electropolished AISI 316	71 Kg Max 3°C min. 95°C max



Construction materials (casing and manifolds) available on request	
DUPLEX/W.DUPLEX	

Specifications and types

STANDARD: II 3G Ex h IIB T4 Gc, II 3D Ex h IIIB T135°C Dc (zone 2)
 CONDUCT: II 2G Ex h IIB T4 Gb, II 2D Ex h IIIB T135°C Db (zone 1)

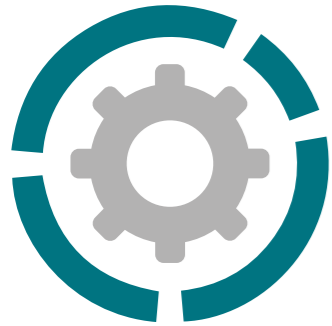

Suction / delivery connections	G 1" flanged ANSI - DN 25
Air fitting	G 3/8" f
Max flow rate	130 l/min
Max supply air pressure	8 bar
Max head	80 m
Max negative suction head - dry-running	4 m
Max negative suction head - pump primed	9.5 m
Max diameter of suspended solids	4 mm
Noise level	75 dB
Volume per stroke	250 cc

- Product designed and constructed in Italy
- PATENTED stall-prevention pneumatic circuit
- Operates with non-lubricated air
- Self-priming
- Dry operation
- Adjustable operating speed
- Extremely versatile
- Suitable for pumping liquids with high viscosity and demanding applications
- Possibility of pumping fluids containing suspended solids
- LONG LIFE profile diaphragms for greater resistance and longer life
- Suitable for continuous use
- Pump made from a solid piece of PTFE
- Non-deformable structure in AISI 316 stainless steel

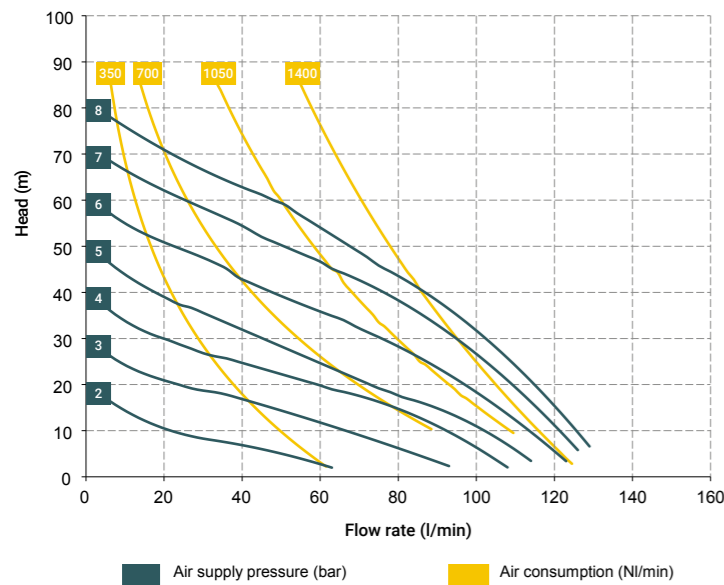

MAIN APPLICATION SECTORS

CHEMICAL INDUSTRY

The curves and the performances refer to pumps with immersed suction and open delivery outlet, with water at 20°C.



PTFE FPC 100



Maximum Dimensions	
Height	300 mm
Width	230 mm
Depth	360 mm



Construction materials (casing and manifolds) and net weight	
PTFE	21.6 Kg Max 3°C min. 95°C max

The Debem FPC100 double diaphragm pump is constructed entirely from a solid piece of PTFE machined with a numeric control machine tool. The pump casing is reinforced with a non-deformable AISI 316 stainless steel structure. All parts in contact with the liquid are made exclusively of PTFE and pump produces a flow rate of 130 l/min.